

FLANGED FITTINGS

- Elbows*
- Tees*
- Crosses*
- Wyes*
- Reducers*
- Flanges*
- Converters*
- Gaskets*
- Nuts & Bolts*

ANSI B16.1 Class 125/150
ANSI B16.1 Class 250

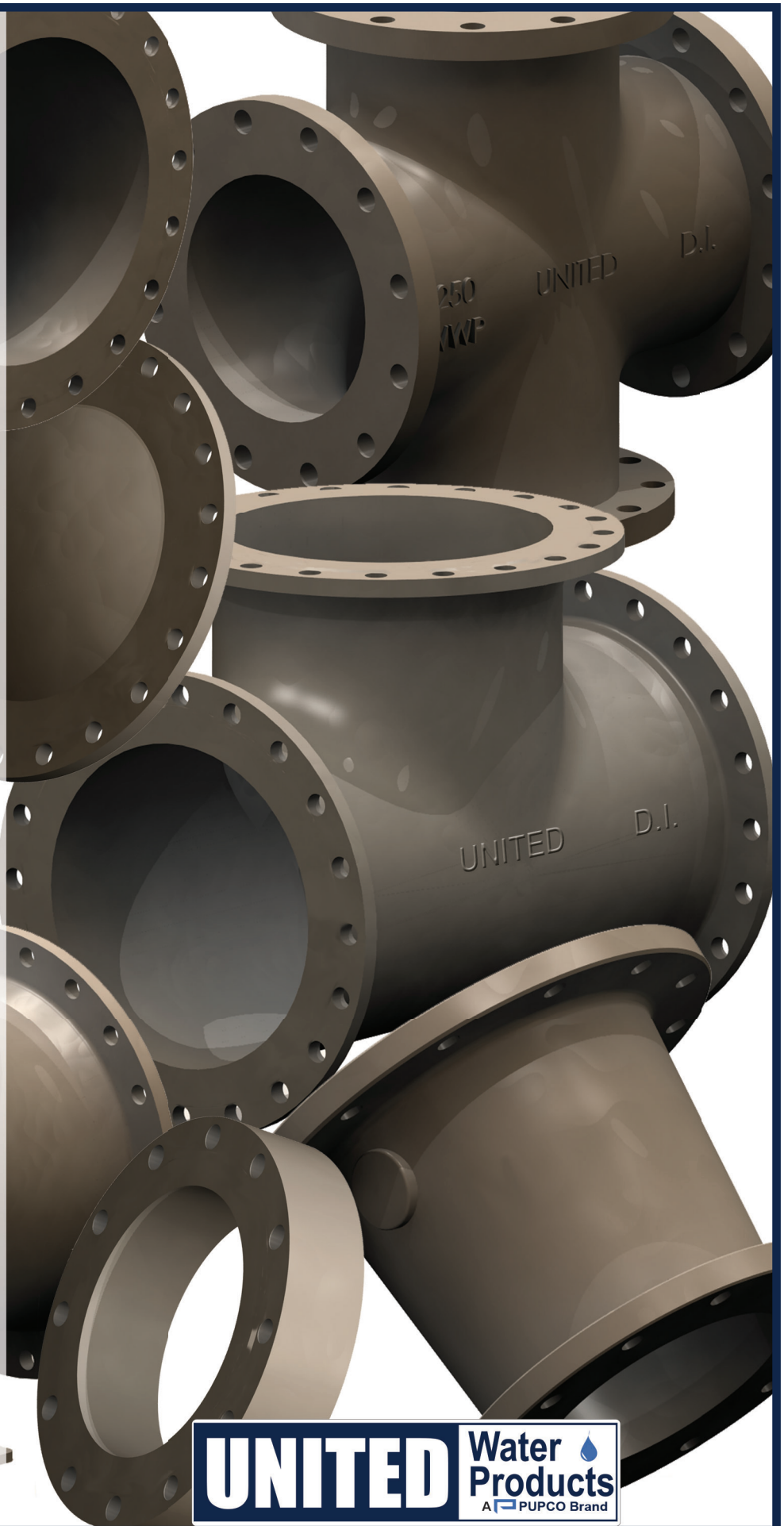

UNITED BRAND FITTINGS

UNITED WATER PRODUCT's dedication to the mechanical piping industry has given us the opportunity to provide our customers with a comprehensive and quality line of flange fittings and threaded flanges which exceed competitive brands.

Our UNITED brand of flange fittings are available in a variety of elbows, tees, crosses, laterals, reducers and blind flanges. Our UNITED brand of threaded flanges are available in a variety of standard and reducing configurations.

Material

Ductile Cast Iron, ASTM A536, Grey Cast Iron, ASTM A126

Flange Fittings – Class 125/150 and 250 Specifications

- Fitting dimensions manufactured in accordance to ASME B16.1
- Made from Ductile Cast Iron ASTM A536
- Flanges faced and drilled in accordance with ANSI B16.1 Class 125/150, Class 250 specifications
- Listed by Underwriter's Laboratory
- Class 125/150 Fittings Available in sizes 2" thru 24" (Sizes above 24" – P.O.A.)
- Class 250/300 Fittings Available in sizes 3" thru 12"
- Galvanizing available upon request (Cold Spray or Hot-Dipped)

Flanges

- Manufactured in accordance to ASTM A126 and ASTM A48.
- Made of Grey Cast Iron ASTM A126
- Faced and drilled in accordance with ANSI B16.1 (Class 125/150, Class 250 specs)
- Threads conform to ASME B1.20.1
- Hot-dipped galvanized flanges - Conform to ASTM A153
- Listed by Underwriter's Laboratory
- Class 125/150 - Sizes 1/2" thru 12"
- Class 250 - Sizes 1" thru 12"

FLANGE DETAILS - Class 125/150

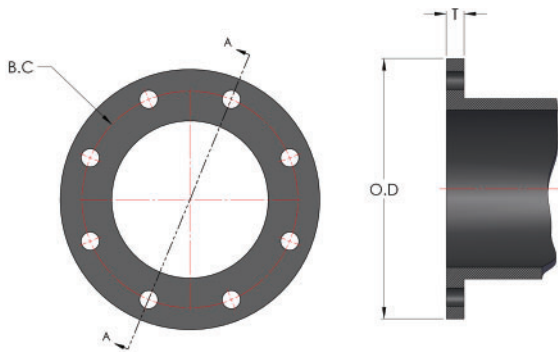

Size	O.D.	B.C.	T	Bolt Hole Dia.	Bolt Dia. & Length	No. of Bolts
2	6.00	4.75	5/8	3/4	5/8 x 2-1/2	4
2-1/2	7.00	5.0	11/16	3/4	5/8 x 2-1/2	4
3	7.50	6.00	3/4	3/4	5/8 x 2-1/2	4
4	9.00	7.50	15/16	3/4	5/8 x 3	8
5	10.00	8.50	15/16	7/8	3/4 x 3-1/2	8
6	11.00	9.50	1	7/8	3/4 x 3-1/2	8
8	13.50	11.75	1-1/8	7/8	3/4 x 3-1/2	8
10	16.00	14.25	1-3/16	1	7/8 x 4	12
12	19.00	17.00	1-1/4	1	7/8 x 4	12
14	21.00	18.75	1/3/8	1-1/8	1 x 4-1/2	12
16	23.50	21.25	1-7/16	1-1/8	1 x 4-1/2	16
18	25.00	22.75	1-9/16	1-1/4	1-1/8 x 5	16
20	27.50	25.00	1-11/16	1-1/4	1-1/8 x 5	20
24	32.00	29.50	1-7/8	1-3/8	1-1/4 x 5-1/2	20

All dimensional data in inches and lbs.

Add suffix "C" for Grey Cast Iron - "D" for Ductile Cast Iron

Larger sizes thru 48" available upon request.

ELBOWS

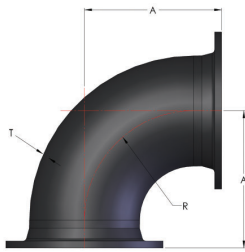

SERIES 10
90°

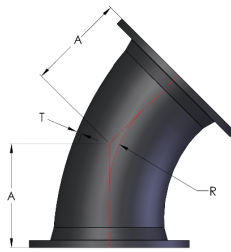

SERIES 11
45°

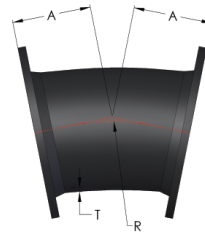

SERIES 12
22 1/2°

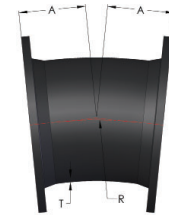

SERIES 13
11 1/4°

Size	90° Elbow				45° Elbow				22 1/2° Elbow				11 1/4° Elbow				T	
	Part No.	A	R	Wgt.	Part No.	A	R	Wgt.	Part No.	A	R	Wgt.	Part No.	A	R	Wgt.		
2	10F-0202-	4.5	3.0	14	11F-0202-	2.5	2.4	12	-	-	-	-	-	-	-	-	-	.31
2-1/2	10F-025025-	5.0	3.5	19	11F-025025-	3.0	3.6	17	-	-	-	-	-	-	-	-	-	.31
3	10F-0303-	5.5	4.0	25	11F-0303-	3.0	3.6	20	12F-0303-	3.0	7.6	20	13F-0303-	3.0	15.25	20	-	.38
4	10F-0404-	6.5	4.5	45	11F-0404-	4.0	4.8	40	12F-0404-	4.0	10.06	40	13F-0404-	4.0	20.31	40	-	.50
5	10F-0505-	7.5	5.5	52	11F-0505-	4.5	6.0	45	-	-	-	-	-	-	-	-	-	.50
6	10F-0606-	8.0	6.0	65	11F-0606-	5.0	7.3	55	12F-0606-	5.0	15.06	55	13F-0606-	5.0	30.50	55	-	.56
8	10F-0808-	9.0	7.0	105	11F-0808-	5.5	8.4	90	12F-0808-	5.5	17.62	90	13F-0808-	5.5	35.50	90	-	.62
10	10F-1010-	11.0	9.0	165	11F-1010-	6.5	10.9	130	12F-1010-	6.5	22.62	135	13F-1010-	6.5	45.69	135	-	.75
12	10F-1212-	12.0	10.0	235	11F-1212-	7.5	13.3	195	12F-1212-	7.5	27.62	205	13F-1212-	7.5	55.81	205	-	.81
14	10F-1414-	14.0	11.5	290	11F-1414-	7.5	12.06	220	-	-	-	-	-	-	-	-	-	.66
16	10F-1616-	15.0	12.5	370	11F-1616-	8.0	13.25	280	-	-	-	-	-	-	-	-	-	.70
18	10F-1818-	16.5	14.0	450	11F-1818-	8.5	14.50	325	-	-	-	-	-	-	-	-	-	.75
20	10F-2020-	18.0	15.5	580	11F-2020-	9.5	16.88	430	-	-	-	-	-	-	-	-	-	.80
24	10F-2424-	22.0	18.5	900	11F-2424-	11.0	18.12	630	-	-	-	-	-	-	-	-	-	.89

90° REDUCING ELBOW

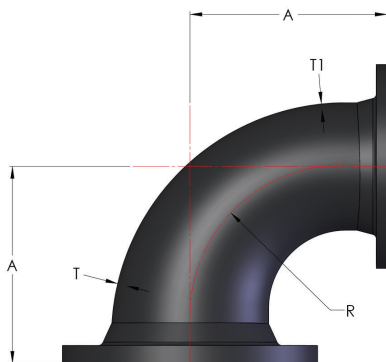

SERIES 10R

Size	Part No.	A	R	T	T1	Weight
3 x 2	10F-0302-	5.5	4.0	.38	.31	19
3 x 2-1/2	10F-03025-	5.5	4.0	.38	.31	22
4 x 2	10F-0402-	6.5	4.0	.50	.31	29
4 x 2-1/2	10F-04025-	6.5	4.0	.50	.31	31
4 x 3	10F-0403-	6.5	4.5	.50	.38	33
5 x 3	10F-0503-	7.5	5.0	.50	.50	44
5 x 4	10F-0504-	7.5	5.0	.50	.50	48
6 x 3	10F-0603-	8.0	6.0	.56	.38	45
6 x 4	10F-0604-	8.0	6.0	.56	.50	55
6 x 5	10F-0605-	8.0	6.0	.56	.50	65
8 x 4	10F-0804-	9.0	7.0	.62	.50	75
8 x 5	10F-0805-	9.0	7.0	.62	.56	80
8 x 6	10F-0806-	9.0	7.0	.62	.56	85
10 x 4	10F-1004-	11.0	9.0	.75	.50	110
10 x 6	10F-1006-	11.0	9.0	.75	.56	135
10 x 8	10F-1008-	11.0	9.0	.75	.62	150
12 x 4	10F-1204-	12.0	10.0	.81	.50	140
12 x 6	10F-1206-	12.0	10.0	.81	.56	160
12 x 8	10F-1208-	12.0	10.0	.81	.62	180
12 x 10	10F-1210-	12.0	10.0	.81	.75	210
14 x 10	10F-1410-	14.0	11.5	.66	.68	240
14 x 12	10F-1412-	14.0	11.5	.66	.75	270
16 x 10	10F-1610-	15.0	12.5	.70	.68	285
16 x 12	10F-1612-	15.0	12.5	.70	.75	310
16 x 14	10F-1614-	15.0	12.5	.70	.66	330

Add suffix "C" for Grey Cast Iron - "D" for Ductile Cast Iron

Larger sizes thru 48" available upon request.

90° LONG RADIUS ELBOW

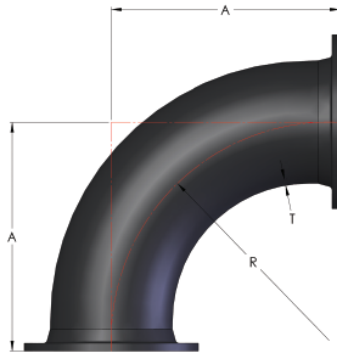

SERIES 15

Size	Part No.	A	R	T	Weight
2	15F-0202-	6.5	5.0	.31	16
2-1/2	15F-025025-	7.0	5.5	.31	23
3	15F-0303-	7.5	6.0	.38	28
4 x 3	15F-0403-	9.0	7.0	.48	38
4	15F-0404-	9.0	7.0	.50	48
6 x 4	15F-0604-	11.5	9.5	.55	70
6	15F-0606-	11.5	9.5	.56	85
8 x 6	15F-0806-	14.0	12.0	.60	116
8	15F-0808-	14.0	12.0	.62	145
10	15F-1010-	16.5	14.0	.75	230
12	15F-1212-	19.0	17.0	.81	350

90° BASE ELBOW

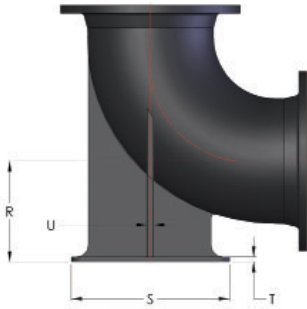

SERIES 16

Size	Part No.	R	S (Dia.)	T	U	Weight
3	16F-0303-	4.0	5.0	.28	.50	36
4	16F-0404-	5.5	6.0	.62	.50	55
6	16F-0606-	7.0	7.0	.69	.62	85
8	16F-0808-	8.38	9.0	.94	.88	145
10	16F-1010-	9.75	9.0	.94	.88	210
12	16F-1212-	11.25	11.0	1.0	1.0	300
14	16F-1414-	12.50	11.0	1.0	1.0	360
16	16F-1616-	13.75	11.0	1.0	1.0	445

SIDE OUTLET 90° ELBOW

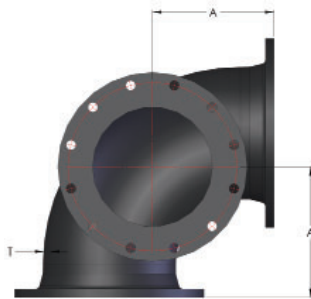

SERIES 18

Size	Part No.	A	R	T	Weight
4	18F-0404-	6.5	6.5	.50	60
6	18F-0606-	8.0	8.0	.56	95
8	18F-0808-	9.0	9.0	.62	150
10	18F-1010-	11.0	11.0	.75	235
12	18F-1212-	12.0	12.0	.81	335

SIDE OUTLET TEE

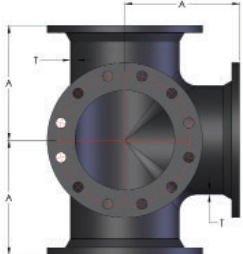

SERIES 19

Size	Part No.	A	T	Weight
4	19F-0404-	6.5	.50	80
6	19F-0606-	8.0	.56	135
8	19F-0808-	9.0	.62	210
10	19F-1010-	11.0	.75	330
12	19F-1212-	12.0	.81	470

Add suffix "C" for Grey Cast Iron - "D" for Ductile Cast Iron

Larger sizes thru 48" available upon request.

TEES & CROSSES

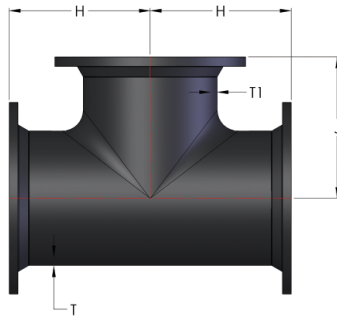

SERIES 20

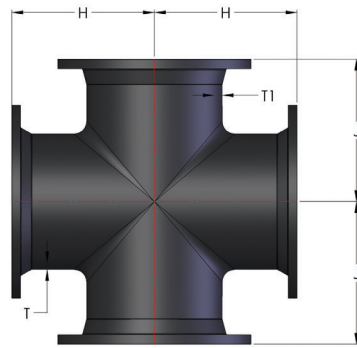

SERIES 35

Size	Part No.		H	J	T	T1	Weight	
	Tee	Cross					Tee	Cross
2	20F-0202-	35F-0202-	4.5	4.5	.31	.31	20	30
2-1/2	20F-025025-	35F-025025-	5.0	5.0	.31	.31	30	39
3 x 2	20F-0302-	-	5.5	5.5	.38	.31	35	-
3 x 2-1/2	20F-03025-	-	5.5	5.5	.38	.31	38	-
3	20F-0303-	35F-0303-	5.5	5.5	.38	.31	40	50
4 x 2	20F-0402-	-	6.5	6.5	.50	.31	50	-
4 x 2-1/2	20F-04025-	-	6.5	6.5	.50	.31	55	-
4 x 3	20F-0403-	-	6.5	6.5	.50	.38	60	-
4	20F-0404-	35F-0404-	6.5	6.5	.50	.50	65	80
5	20F-0505-	35F-0505-	7.5	7.5	.50	.50	85	105
6 x 2	20F-0602-	-	8.0	8.0	.56	.31	86	-
6 x 3	20F-0603-	-	8.0	8.0	.56	.38	85	-
6 x 4	20F-0604-	35F-0604-	8.0	8.0	.56	.50	90	110
6 x 5	20F-0605-	-	8.0	8.0	.56	.53	92	-
6	20F-0606-	35F-0606-	8.0	8.0	.56	.56	95	120
8 x 3	20F-0803-	-	9.0	9.0	.62	.38	140	-
8 x 4	20F-0804-	-	9.0	9.0	.62	.50	140	155
8 x 6	20F-0806-	35F-0806-	9.0	9.0	.62	.56	145	165
8	20F-0808-	35F-0808-	9.0	9.0	.62	.62	155	195
10 x 3	20F-1003-	-	11.0	11.0	.75	.38	200	-
10 x 4	20F-1004-	-	11.0	11.0	.75	.50	205	-
10 x 6	20F-1006-	-	11.0	11.0	.75	.56	215	240
10 x 8	20F-1008-	-	11.0	11.0	.75	.62	225	265
10	20F-1010-	35F-1010-	11.0	11.0	.75	.75	270	330
12 x 4	20F-1204-	-	12.0	12.0	.81	.50	290	-
12 x 6	20F-1206-	-	12.0	12.0	.81	.56	295	320
12 x 8	20F-1208-	-	12.0	12.0	.81	.62	310	345
12 x 10	20F-1210-	-	12.0	12.0	.81	.75	360	415
12	20F-1212-	35F-1212-	12.0	12.0	.81	.81	385	460
14	20F-1414-	35F-1414-	14.0	14.0	.66	.66	435	595
16	20F-1616-	35F-1616-	15.0	15.0	.70	.70	550	755
18	20F-1818-	35F-1818-	16.5	16.5	.75	.75	665	915
20	20F-2020-	35F-2020-	18.0	18.0	.80	.80	855	1175
24	20F-2424-	35F-2424-	22.0	22.0	.89	.89	1330	1850

REDUCING TEE (on Run and/or Branch)

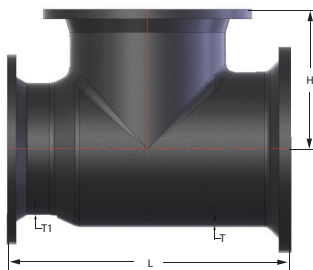

SERIES 26

Size	Part No.	H	L	T	T1	Weight
4 x 3 x 4	26F-0434-	6.5	13.0	.50	.38	59
6 x 4 x 4	26F-0644-	8.0	16.0	.56	.50	90
6 x 4 x 6	26F-0646-	8.0	16.0	.56	.50	95
8 x 4 x 8	26F-0848-	9.0	18.0	.62	.50	146
8 x 6 x 4	26F-0864-	9.0	18.0	.62	.56	125
8 x 6 x 6	26F-0866-	9.0	18.0	.62	.56	145
8 x 6 x 8	26F-0868-	9.0	18.0	.62	.56	160
10 x 8 x 8	26F-1088-	11.0	22.0	.75	.62	232
10 x 8 x 10	26F-10810-	11.0	22.0	.75	.62	262
12 x 8 x 8	26F-1288-	12.0	24.0	.81	.62	298
12 x 10 x 10	26F-121010-	12.0	24.0	.81	.75	340
12 x 10 x 12	26F-121012-	12.0	24.0	.81	.75	365

Add suffix "C" for Grey Cast Iron - "D" for Ductile Cast Iron

Larger sizes thru 48" available upon request.

BULLHEAD TEE

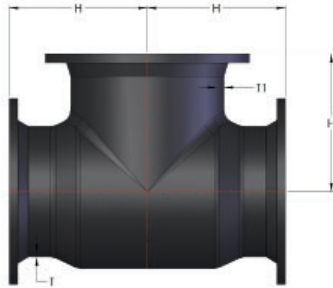

SERIES 27

Size	Part No.	H	J	T	T1	Weight
4 x 4 x 6	27F-446-	8.0	8.0	.50	.56	88
6 x 6 x 8	27F-668-	9.0	9.0	.56	.62	142
8 x 8 x 10	27F-8810-	11.0	11.0	.62	.75	240
10 x 10 x 12	27F-101012-	12.0	12.0	.75	.81	340

TRUE WYES

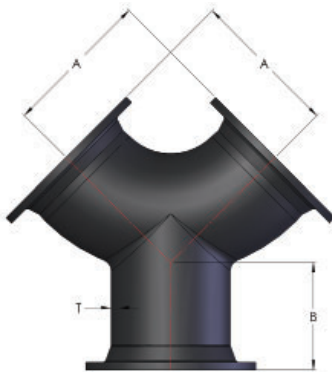

SERIES 32

Size	Part No.	A	B	T	Weight
4	32F-0404-	6.5	3.0	.50	50
6	32F-0606-	8.0	3.5	.56	80
8	32F-0808-	9.0	4.5	.62	125

LATERAL WYES

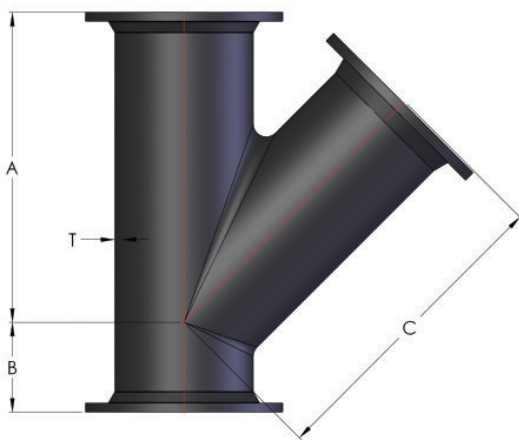

SERIES 30

Size	Part No.	A	B	C	T	Weight
3	30F-0303-	10.0	3.0	10.0	.38	45
4 x 3	30F-0403-	12.0	3.0	12.0	.52	65
4	30F-0404-	12.0	3.0	12.0	.50	75
6 x 3	30F-0603-	14.5	3.0	12.0	.55	100
6 x 4	30F-0604-	14.5	3.5	14.5	.56	105
6	30F-0606-	14.5	3.5	14.5	.56	120
8 x 6	30F-0806-	17.5	4.5	17.5	.62	175
8	30F-0808-	17.5	4.5	17.5	.62	200
10 x 6	30F-1006-	20.5	5.0	20.5	.68	270
10 x 8	30F-1008-	20.5	5.0	20.5	.68	295
10	30F-1010-	20.5	5.0	20.5	.75	335
12 x 6	30F-1206-	24.5	5.5	24.5	.75	395
12 x 8	30F-1208-	24.5	5.5	24.5	.75	420
12 x 10	30F-1210-	24.5	5.5	24.5	.75	455
12	30F-1212-	24.5	5.5	24.5	.81	515

Add suffix "C" for Grey Cast Iron - "D" for Ductile Cast Iron

Larger sizes thru 48" available upon request.

CONCENTRIC & ECCENTRIC REDUCERS

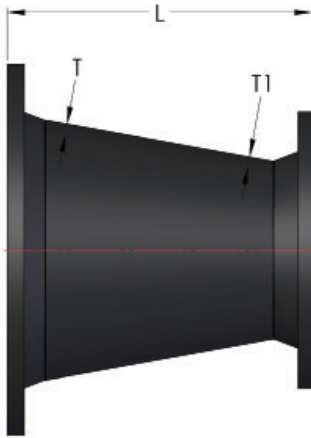

(CONCENTRIC)
SERIES 50

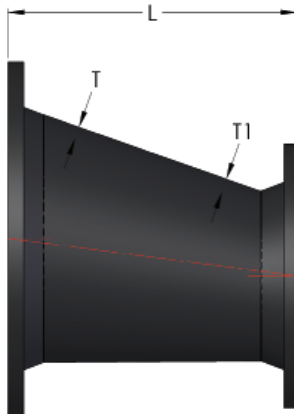

(ECCENTRIC)
SERIES 51

Size	Part No. (Concentric)	Part No. (Eccentric)	L	T	T1	Weight
2 x 1-1/2	50F-02015-	-	5.5	.31	.30	12
2-1/2 x 2	50F-02502-	-	5.5	.31	.31	14
3 x 1-1/2	50F-03015-	-	6	.38	.30	15
3 x 2	50F-0302-	51F-0302-	6	.38	.31	16
3 x 2-1/2	50F-03025-	51F-03025-	6	.38	.31	20
4 x 2	50F-0402-	51F-0402-	7	.50	.31	25
4 x 2-1/2	50F-04025-	51F-04025-	7	.50	.31	28
4 x 3	50F-0403-	51F-0403-	7	.50	.38	30
5 x 2-1/2	50F-05025-	51F-05025-	8	.50	.31	31
5 x 3	50F-0503-	51F-0503-	8	.50	.38	32
5 x 4	50F-0504-	51F-0504-	8	.50	.50	39
6 x 2	50F-0602-	51F-0602-	9	.56	.31	35
6 x 2-1/2	50F-06025-	51F-06025-	9	.56	.31	38
6 x 3	50F-0603-	51F-0603-	9	.56	.38	40
6 x 4	50F-0604-	51F-0604-	9	.56	.50	45
6 x 5	50F-0605-	51F-0605-	9	.56	.50	50
8 x 3	50F-0803-	51F-0803-	11	.62	.38	57
8 x 4	50F-0804-	51F-0804-	11	.62	.50	65
8 x 5	50F-0805-	51F-0805-	11	.62	.50	70
8 x 6	50F-0806-	51F-0806-	11	.62	.56	75
10 x 4	50F-1004-	51F-1004-	12	.75	.50	85
10 x 5	50F-1005-	51F-1005-	12	.75	.50	88
10 x 6	50F-1006-	51F-1006-	12	.75	.56	90
10 x 8	50F-1008-	51F-1008-	12	.75	.62	110
12 x 4	50F-1204-	51F-1204-	14	.81	.50	120
12 x 6	50F-1206-	51F-1206-	14	.81	.56	130
12 x 8	50F-1208-	51F-1208-	14	.81	.62	145
12 x 10	50F-1210-	51F-1210-	14	.81	.75	170
14 x 6	50F-1406-	51F-1406-	16	.66	.55	155
14 x 8	50F-1408-	51F-1408-	16	.66	.60	175
14 x 10	50F-1410-	51F-1410-	16	.66	.68	190
14 x 12	50F-1412-	51F-1412-	16	.66	.75	220
16 x 6	50F-1606-	51F-1606-	18	.70	.55	190
16 x 8	50F-1608-	51F-1608-	18	.70	.60	210
16 x 10	50F-1610-	51F-1610-	18	.70	.68	235
16 x 12	50F-1612-	51F-1612-	18	.70	.75	265
16 x 14	50F-1614-	51F-1614-	18	.70	.66	280
18 x 8	50F-1808-	51F-1808-	19	.75	.60	240
18 x 10	50F-1810-	51F-1810-	19	.75	.68	265
18 x 12	50F-1812-	51F-1812-	19	.75	.75	295
18 x 14	50F-1814-	51F-1814-	19	.75	.66	310
18 x 16	50F-1816-	51F-1816-	19	.75	.70	340
20 x 10	50F-2010-	51F-2010-	20	.80	.68	310
20 x 12	50F-2012-	51F-2012-	20	.80	.75	345
20 x 14	50F-2014-	51F-2014-	20	.80	.66	355
20 x 16	50F-2016-	51F-2016-	20	.80	.70	390
20 x 18	50F-2018-	51F-2018-	20	.80	.75	410
24 x 12	50F-2412-	51F-2412-	24	.89	.75	480
24 x 14	50F-2414-	51F-2414-	24	.89	.66	490
24 x 16	50F-2416-	51F-2416-	24	.89	.70	525
24 x 18	50F-2418-	51F-2418-	24	.89	.75	550
24 x 20	50F-2420-	51F-2420-	24	.89	.80	590

Add suffix "C" for Grey Cast Iron - "D" for Ductile Cast Iron

Larger sizes thru 48" available upon request.

STANDARD COMPANION FLANGE (Cast Iron)

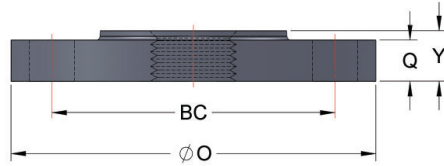

SERIES 306

Nominal Size	Product No.	BC	O	Q	Y	Bolt Holes		Wgt.
						No.	Size	
1	306-100-0425	3.12	4-1/4	7/16	11/16	4	0.62	1.75
1-1/4	306-125-0463	3.50	4-5/8	1/2	13/16	4	0.62	2.00
1-1/2	306-150-0500	3.88	5	9/16	7/8	4	0.62	2.25
2	306-200-0600	4.75	6	5/8	1	4	0.75	4.00
2-1/2	306-250-0700	5.50	7	11/16	1-1/8	4	0.75	6.00
3	306-300-0750	6.00	7-1/2	3/4	1-3/16	4	0.75	7.63
3-1/2	306-350-0850	7.00	8-1/2	13/16	1-1/4	8	0.75	9.50
4	306-400-0900	7.50	9	15/16	1-5/16	8	0.75	11.75
5	306-500-1000	8.50	10	15/16	1-7/16	8	0.88	14.00
6	306-600-1100	9.50	11	1	1-9/16	8	0.88	16.50
8	306-800-1350	11.75	13-1/2	1-1/8	1-3/4	8	0.88	26.00
10	306-1000-1600	14.25	16	1-3/16	1-15/16	12	1.00	38.00
12	306-1200-1900	17.00	19	1-1/4	2-3/16	12	1.00	51.00

REDUCING COMPANION FLANGE (Cast Iron)

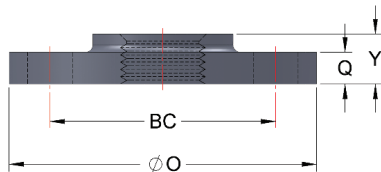

SERIES 316

Nominal Size		Product No.	Thread Size	BC	O	Q	Y	Bolt Holes		Weight
Pipe x O.D.	Flg. x Pipe							No.	Size	
1 x 5	1-1/2 x 1	316-100-0500	1	3.88	5	9/16	11/16	4	0.62	2.75
1-1/4 x 5	1-1/2 x 1-1/4	316-125-0500	1-1/4				13/16			2.50
1 x 6	2 x 1	316-100-0600	1				11/16			5.00
1-1/4 x 6	2 x 1-1/4	316-125-0600	1-1/4	4.75	6	5/8	13/16	4	0.75	4.75
1-1/2 x 6	2 x 1-1/2	316-150-0600	1-1/2				7/8			4.50
1-1/2 x 7	2-1/2 x 1-1/2	316-150-0700	1-1/2				7/8	4	0.75	7.00
2 x 7	2-1/2 x 2	316-200-0700	2	5.50	7	11/16	1			6.75
1 x 7-1/2	3 x 1	316-100-0750	1				13/16			9.00
1-1/2 x 7-1/2	3 x 1-1/2	316-150-0750	1-1/2				7/8	4	0.75	8.75
2 x 7-1/2	3 x 2	316-200-0750	2	6.00	7-1/2	3/4	1			8.50
2-1/2 x 7-1/2	3 x 2-1/2	316-250-0750	2-1/2				1-1/8			8.00
1-1/2 x 9	4 x 1-1/2	316-150-0900	1-1/2				1			14.75
2 x 9	4 x 2	316-200-0900	2				1			14.00
2-1/2 x 9	4 x 2-1/2	316-250-0900	2-1/2	7.50	9	15/16	1-1/8	8	0.75	13.50
3 x 9	4 x 3	316-300-0900	3				1-3/16			12.75
2 x 10	5 x 2	316-200-1000	2				1			18.00
3 x 10	5 x 3	316-300-1000	3	8.50	10	15/16	1-3/16	8	0.88	17.00
4 x 10	5 x 4	316-400-1000	4				1-5/16			16.00
1-1/2 x 11	6 x 1-1/2	316-150-1100	1-1/2				1-1/16			27.00
2 x 11	6 x 2	316-200-1100	2				1-1/16			26.00
2-1/2 x 11	6 x 2-1/2	316-250-1100	2-1/2	9.50	11	1	1-1/8	8	0.88	25.00
3 x 11	6 x 3	316-300-110	3				1-3/16			23.00
4 x 11	6 x 4	316-400-1100	4				1-5/16			21.00
5 x 11	6 x 5	316-500-1100	5				1-7/16			19.00
2 x 13-1/2	8 x 2	316-200-1350	2				1-3/16			4.00
3 x 13-1/2	8 x 3	316-300-1350	3				1-3/16			40.00
4 x 13-1/2	8 x 4	316-400-1350	4	11.75	13-1/2	1-1/8	1-5/16	8	0.88	37.00
5 x 13-1/2	8 x 5	316-500-1350	5				1-7/16			34.00
6 x 13-1/2	8 x 6	316-600-1350	6				1-9/16			31.00
2 x 16	10 x 2	316-200-1600	2				1-15/16			61.00
4 x 16	10 x 4	316-400-1600	4				1-15/16			57.00
6 x 16	10 x 6	316-600-1600	6	14.25	16	1-3/16	1-15/16	12	1.00	53.00
8 x 16	10 x 8	316-800-1600	8				1-15/16			50.00
2 x 19	12 x 2	316-200-1900	2				2-3/16			84.00
4 x 19	12 x 4	316-400-1900	4				2-3/16			86.00
6 x 19	12 x 6	316-600-1900	6	17.00	19	1-1/4	2-3/16	12	1.00	88.00
8 x 19	12 x 8	316-800-1900	8				2-3/16			81.00
10 x 19	12 x 10	316-1000-1900	10				2-3/16			72.00

Add suffix "C" for Grey Cast Iron - "D" for Ductile Cast Iron

Larger sizes thru 48" available upon request.

REDI-FLANGE™

No Welding!
No Threading!

STANDARDS:

Ductile Iron - ASTM A536
Grade 65-45-12. Drilling to
ANSI B16.1 - 125 lb.
ANSI B16.5 - 150 lb.

SET SCREW: AISI

steel. Tensile 160,000
psi minimum.

GASKET: SBR (BUNA-N).

HYDROSTATIC TEST PRESSURE:

MODEL - RFC-2/RFS-2 - 125
lb./150 lb.

2 in. - 8 in. 600 psi
10 in. - 12 in. 525 psi

MODEL - RFC-4 - 125 lb./150 lb.
14 in. - 24 in. 300 psi

The *Redi-Flange*™ joins valves, fittings and equipment with integral flanged ends to plain end pipe, without the need of pipe end preparation. Absolutely no threading, welding, or grooving is necessary. The working principle of the *Redi-Flange*™ is relatively simple. Slide the flange over plain end pipe and follow it with a standard mechanical joint gasket. When the *Redi-Flange*™ is brought to mate against an existing flange, and the flange bolts are tightened, a compression type seal is created against the mating flange and pipe surface. End restraint is provided when the set screws are tightened.

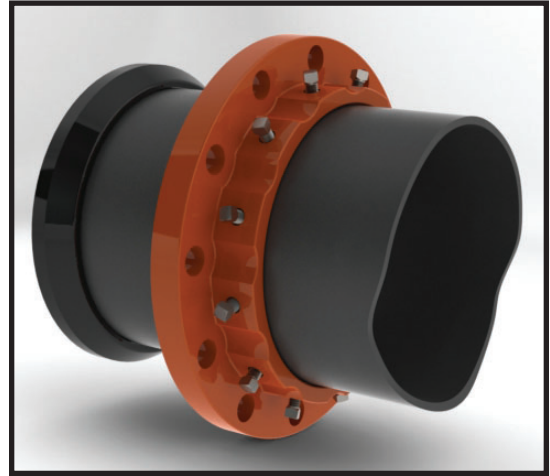

Nom. Pipe Size	Part No.	D.I. Pipe O.D. RFC-2-D	Steel Pipe O.D. RFS-2-S	Flange O.D.	Bolt Circle	Bolt Hole Dia.	Set Screws		Wgt. Approx.
							No.	Size	
2	RFC-201	2.50	2.38	6	4-3/4	3/4	2	1/2 x 1	3.5
2-1/2	RFC-202	-	2.88	7	5-1/2	3/4	4	1/2 x 1	4
*3	RFC-203	3.96	3.50	7-1/2	6	3/4	4	1/2 x 1	5
*4	RFC-204	4.80	4.50	9	7-1/2	3/4	4	1/2 x 1	8
5	RFC-205	-	5.56	10	8-1/2	7/8	8	1/2 x 1	9
*6	RFC-206	6.90	6.625	11	9-1/2	7/8	8	1/2 x 1	10
*8	RFC-208	9.05	8.625	13-1/2	11-3/4	7/8	8	5/8 x 1 1/4	17
*10	RFC-210	11.10	10.75	16	14-1/4	1	12	5/8 x 1-1/4	22
12	RFC-212	13.20	12.75	19	17	1	12	5/8 x 1-1/4	31

Use Prefix RFC for DI Pipe - RFS for Steel Pipe

Nom. Pipe Size	Part No.	D.I. Pipe O.D. RFC-4-D	Flange O.D.	Bolt Circle	Bolt Hole Dia.	Set Screws		Wgt. Approx.
						No.	Size	
14	RFC-414	15.30	21	18-3/4	1-1/8	12	5/8 x 1-1/4	70
16	RFC-416	17.40	23-1/2	21-1/4	1-1/8	16	5/8 x 1-1/4	79
18	RFC-418	19.50	25	22-3/4	1-1/4	16	3/4 x 2	90
20	RFC-420	21.60	27-1/2	25	1-1/4	20	3/4 x 2	145
24	RFC-424	25.80	32	29-1/2	1-3/8	20	3/4 x 2	175
30	RFC-430	32.00	38-3/4	36	1-3/8	28	1 x 2-1/4	270
36	RFC-436	38.30	46	42-3/4	1-5/8	32	1 x 2-1/4	400
42	RFC-442	44.50	53	49-1/2	1-5/8	36	1 x 2-1/4	495
48	RFC-448	50.80	59-1/2	56	1-5/8	44	1 x 2-1/4	660

*Denotes UL Listed

Add suffix "C" for Grey Cast Iron - "D" for Ductile Cast Iron

Larger sizes thru 48" available upon request.

COMPACT FLANGE REDUCER

Class 125/150 Flanges

Mates with ANSI Class 125/150 flange drillings

Material: Ductile Iron - ASTM A536 or ASTM A36 Steel

TYPE A

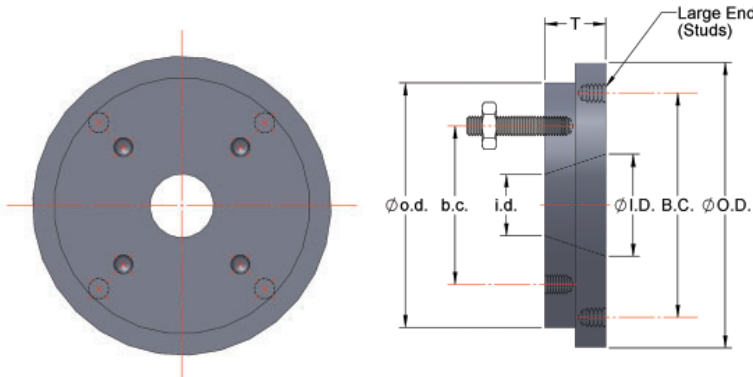

TYPE B

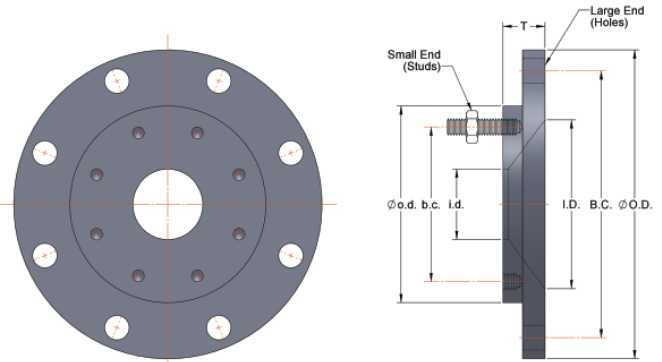

Flange Size	Part No.	Large End			Small End			T	Type	Large End Studs		Small End Studs	
		I.D.	O.D.	B.C.	i.d.	o.d.	b.c.			Qty.	Size	Qty.	Size
2 x 1-1/2	740-110-100	2.00	6.00	4.75	1.50	6.00	3.88	1.50	A	4	5/8 x 2-1/2	4	1/2 x 2-1/2
2 1/2 x 1-1/2	740-120-100	2.50	7.00	5.50	1.50	6.00	3.88	1.50	A	4	5/8 x 2-1/2	4	1/2 x 2-1/2
2 1/2 x 2	740-120-110	2.50	7.00	5.50	2.00	6.00	4.75	1.50	A	4	5/8 x 2-1/2	4	5/8 x 2-1/2
3 x 1-1/2	740-130-100	3.00	7.50	6.00	1.50	6.00	3.88	1.50	A	4	5/8 x 2-1/2	4	1/2 x 2-1/2
3 x 2	740-130-110	3.00	7.50	6.00	2.00	6.00	4.75	1.50	A	4	5/8 x 2-1/2	4	5/8 x 2-1/2
3 x 2-1/2	740-130-120	3.00	7.50	6.00	2.50	7.00	5.50	1.50	A	4	5/8 x 2-1/2	4	5/8 x 2-1/2
4 x 2	740-140-110	4.00	9.00	7.50	2.00	6.00	4.75	1.50	A	8	5/8 x 3	4	5/8 x 2-1/2
4 x 2-1/2	740-140-120	4.00	9.00	7.50	2.50	7.00	5.50	1.50	A	8	5/8 x 3	4	5/8 x 2-1/2
4 x 3	740-140-130	4.00	9.00	7.50	3.00	7.50	6.00	1.50	A	8	5/8 x 3	4	5/8 x 2-1/2
6 x 2-1/2	790-160-120	6.00	11.00	9.50	2.50	7.00	5.50	1.50	B	-	-	4	5/8 x 2-1/2
6 x 3	790-160-130	6.00	11.00	9.50	3.00	7.50	6.00	1.50	B	-	-	4	5/8 x 2-1/2
6 x 4	740-160-140	6.00	11.00	9.50	4.00	9.00	7.50	2.00	A	8	3/4 x 3-1/2	8	5/8 x 3
6 x 5	740-160-150	6.00	11.00	9.50	5.00	10.00	8.50	2.00	A	8	3/4 x 3-1/2	8	3/4 x 3-1/2
8 x 4	790-180-140	8.00	13.50	11.75	4.00	9.00	7.50	2.00	B	-	-	8	5/8 x 3
8 x 5	740-180-150	8.00	13.50	11.75	5.00	10.00	8.50	2.00	A	8	3/4 x 3-1/2	8	3/4 x 3-1/2
8 x 6	740-180-160	8.00	13.50	11.75	6.00	11.00	9.50	2.00	A	8	3/4 x 3-1/2	8	3/4 x 3-1/2
10 x 2	790-200-110	10.00	16.00	14.25	2.00	6.00	4.75	1.50	B	-	-	4	5/8 x 2-1/2
10 x 4	790-200-140	10.00	16.00	14.25	4.00	9.00	7.50	2.00	B	-	-	8	5/8 x 3
10 x 5	790-200-150	10.00	16.00	14.25	5.00	10.00	8.50	2.00	B	-	-	8	3/4 x 3-1/2
10 x 6	740-200-160	10.00	16.00	14.25	6.00	11.00	9.50	2.00	A	12	7/8 x 4	8	3/4 x 3-1/2
10 x 8	740-200-180	10.00	16.00	14.25	8.00	13.50	11.75	2.00	A	12	7/8 x 4	8	3/4 x 3-1/2
12 x 4	790-220-140	12.00	19.00	17.00	4.00	9.00	7.50	2.00	B	-	-	8	5/8 x 3
12 x 6	790-220-160	12.00	19.00	17.00	6.00	11.00	9.50	2.00	B	-	-	8	3/4 x 3-1/2
12 x 8	740-220-180	12.00	19.00	17.00	8.00	13.50	11.75	2.00	A	12	7/8 x 4	8	3/4 x 3-1/2
12 x 10	740-220-200	12.00	19.00	17.00	10.00	16.00	14.25	2.00	A	12	7/8 x 4	12	7/8 x 4
14 x 6	790-240-160	14.00	21.00	18.75	6.00	11.00	9.50	2.50	B	-	-	8	3/4 x 3-1/2
14 x 8	790-240-180	14.00	21.00	18.75	8.00	13.50	11.75	2.50	B	-	-	8	3/4 x 3-1/2
14 x 10	740-240-200	14.00	21.00	18.75	10.00	16.00	14.25	2.50	A	12	1 x 4-1/2	12	7/8 x 4
14 x 12	740-240-220	14.00	21.00	18.75	12.00	19.00	17.00	2.50	A	12	1 x 4-1/2	12	7/8 x 4
16 x 6	790-260-160	16.00	23.50	21.25	3.00	11.00	9.50	2.50	B	-	-	8	3/4 x 3-1/2
16 x 8	790-260-180	16.00	23.50	21.25	8.00	13.50	11.75	2.50	B	-	-	8	3/4 x 3-1/2
16 x 10	790-260-200	16.00	23.50	21.25	10.00	16.00	14.25	2.50	B	-	-	12	7/8 x 4
16 x 12	740-260-220	16.00	23.50	21.25	12.00	19.00	17.00	2.50	A	16	1 x 4-1/2	12	7/8 x 4
16 x 14	740-260-240	16.00	23.50	21.25	14.00	21.00	18.75	2.50	A	16	1 x 4-1/2	12	1 x 4-1/2
18 x 12	740-280-220	18.00	25.00	22.75	12.00	19.00	17.00	2.50	B	-	-	12	7/8 x 4
20 x 12	740-300-220	20.00	27.50	25.00	12.00	19.00	17.00	2.50	B	-	-	12	7/8 x 4

Add suffix "C" for Grey Cast Iron - "D" for Ductile Cast Iron

Larger sizes thru 48" available upon request.

BLIND FLANGES



SERIES 60 (1"~10")

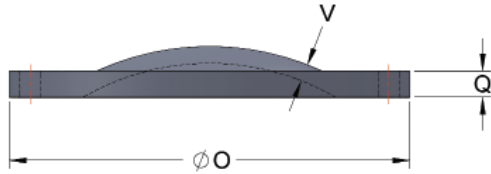

SERIES 60 (12")

Size	Part No.	O	Q	V	Weight
1	60F-0100-	4.25	.44	.38	2
1-1/4	60F-0125-	4.62	.50	.44	2.25
1-1/2	60F-0150-	5.00	.56	.50	3.75
2	60F-0200-	6.00	.62	.62	5
2-1/2	60F-0250-	7.00	.68	.62	7
3	60F-0300-	7.50	.75	.69	9
3-1/2	60F-0350-	8.50	.81	.75	14
4	60F-0400-	9.00	.94	.88	16
5	60F-0500-	10.00	.94	.88	18
6	60F-0600-	11.00	1.00	.94	25
8	60F-0800-	13.50	1.12	1.06	42
10	60F-1000-	16.00	1.19	1.12	62
12	60F-1200-	19.00	1.25	.81	85
14	60F-1400-	21.00	1.38	.88	120
16	60F-1600-	23.50	1.44	1.00	145
18	60F-1800-	25.00	1.56	1.06	185
20	60F-2000-	27.50	1.69	1.12	245
24	60F-2400-	32.00	1.88	1.25	370

FLANGE CONVERTERS

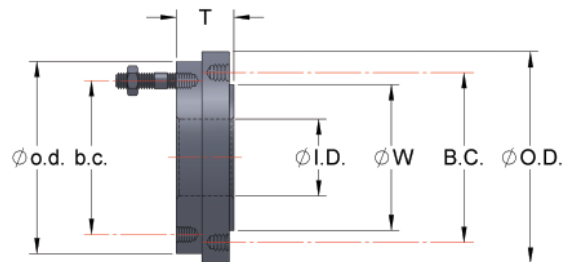

Class 125/150

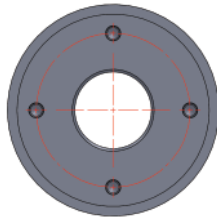

Class 250/300

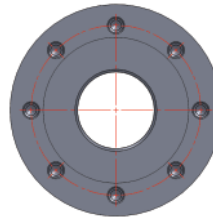

Part No.	CLASS 125/150					CLASS 250/300							Weight
	Flange Size/I.D.	o.d.	b.c.	No. of Bolt Holes	Stud Bolt Size	W	B.C.	O.D.	A	T	No. of Bolt Holes	Stud Bolt Size	
840-130	3	7.50	6.0	4	5/8 x 3	5.69	6.62	8.25	0.06	2	8	3/4 x 3-1/2	24
840-140	4	9	7.5	8	5/8 x 3	6.94	7.88	10	0.06	2	8	3/4 x 4	28
840-150	5	10	8.5	8	3/4 x 3-1/2	8.31	9.25	11	0.06	2	8	3/4 x 4	32
840-160	6	11	9.5	8	3/4 x 3-1/2	9.69	10.62	12.5	0.06	2	12	3/4 x 4	42
840-180	8	13.5	11.75	8	3/4 x 3-1/2	11.94	13	15	0.06	2 1/4	12	7/8 x 4-1/2	66
840-200	10	16	14.25	12	7/8 x 4	14.06	15.25	17.5	0.06	2 3/4	16	1 x 5-1/2	100
840-220	12	19	17	12	7/8 x 4	16.44	17.75	20.5	0.06	2 3/4	16	1-1/8 x 5-1/2	160

Add suffix "C" for Grey Cast Iron - "D" for Ductile Cast Iron

Larger sizes thru 48" available upon request.

FILLER FLANGE

ANSI B16.1 Class 125/150 (2"~24")

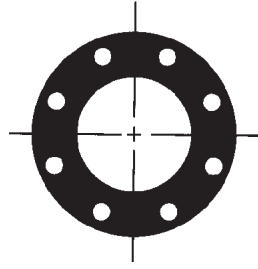

Straight Filler



Beveled Filler

Size	O.D.	Length						Part Number					
		1/2"	3/4"	1"	2"	3"	4"	1/2"	3/4"	1"	2"	3"	4"
3"	7.50	4.5	6.75	9	18	28	36	590-03-D	5905-03-D	591-03-D	592-03-D	593-03-D	594-03-D
4"	9.00	6	9	12	25	37	50	590-04-D	5905-04-D	591-04-D	592-04-D	593-04-D	594-04-D
6"	11.00	8	12	16	32	48	64	590-06-D	5905-06-D	591-06-D	592-06-D	593-06-D	594-06-D
8"	13.50	11.5	17.25	23	46	69	92	590-08-D	5905-08-D	591-08-D	592-08-D	593-08-D	594-08-D
10"	16.00	14.5	21.75	29	59	88	118	590-10-D	5905-10-D	591-10-D	592-10-D	593-10-D	594-10-D
12"	19.00	21	31.50	42	84	136	168	590-12-D	5905-12-D	591-12-D	592-12-D	593-12-D	594-12-D
14"	21.00	23.5	35.25	47	94	141	188	590-14-D	5905-14-D	591-14-D	592-14-D	593-14-D	594-14-D
16"	23.50	28	42	56	113	169	226	590-16-D	5905-16-D	591-16-D	592-16-D	593-16-D	594-16-D
18"	25.00	31	46.5	62	123	184	246	590-18-D	5905-18-D	591-18-D	592-18-D	593-18-D	594-18-D
20"	27.50	33	49.50	66	133	199	266	590-20-D	5905-20-D	591-20-D	592-20-D	593-20-D	594-20-D
24"	32.00	42	63	84	168	251	336	590-24-D	5905-24-D	591-24-D	592-24-D	593-24-D	594-24-D
30"	38.75	56	84	112	224	336	448	590-30-D	5905-30-D	591-30-D	592-30-D	593-30-D	594-30-D
36"	46.00	75	112.50	150	300	451	600	590-36-D	5905-36-D	591-36-D	592-36-D	593-36-D	594-36-D
42"	53.00	97	145.50	194	388	582	776	590-42-D	5905-42-D	591-42-D	592-42-D	593-42-D	594-42-D
48"	59.50	114.5	171.75	229	457	686	915	590-48-D	5905-48-D	591-48-D	592-48-D	593-48-D	594-48-D

DUCTILE IRON FLANGED PIPES

Integrally Cast

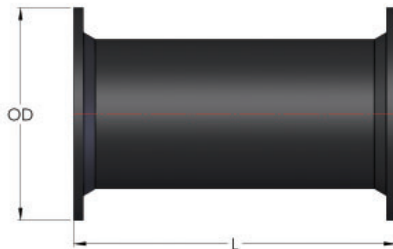

Part Number	Size (ND)	Length	Weight (Approx.)
80F-0406-	4"	6"	29.00
80F-0412-		12"	35.92
80F-0418-		18"	42.87
80F-0424-		24"	49.79
80F-0606-	6"	6"	41.10
80F-0612-		12"	52.19
80F-0618-		18"	63.28
80F-0624-		24"	74.37
80F-0806-	8"	6"	110.89
80F-0812-		12"	127.16
80F-0818-		18"	141.65
80F-0824-		24"	157.04

Add suffix "C" for Grey Cast Iron - "D" for Ductile Cast Iron

Larger sizes thru 48" available upon request.

SEAL-TITE FLANGE GASKET

Low Torque!

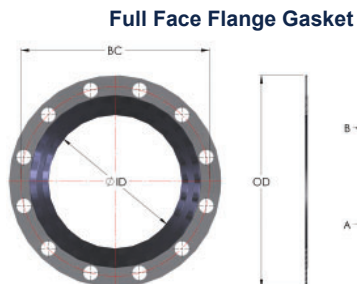

Ring Type Flange Gasket

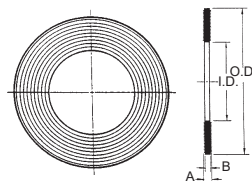

Serrated Face!

Material: SBR

Nominal Size	Part No. (Full Face)	Part No. (Ring)	ID	OD (Full Face)	OD (Ring)	A	B	BC (Full Face)	Box Quantity (Full Face)	Box Quantity (Ring)
2	FFG-050-150	RG-050-100	2.15	6.00	3.90	5/32	1/8	4.75	25	25
2 1/2	FFG-065-175	RG-065-120	2.73	7.00	4.70	5/32	1/8	5.50	25	25
3	FFG-080-188	RG-080-132	3.20	7.50	5.15	5/32	1/8	6.00	25	25
4	FFG-100-210	RG-100-162	3.98	9.00	6.30	5/32	1/8	7.50	25	25
5	FFG-125-250	RG-125-194	5.07	10.00	7.60	5/32	1/8	8.50	25	25
6	FFG-150-275	RG-150-218	6.01	11.00	8.50	5/32	1/8	9.50	25	25
8	FFG-200-340	RG-200-272	8.11	13.50	10.60	5/32	1/8	11.75	25	25
10	FFG-250-400	RG-250-328	10.06	16.00	12.80	5/32	1/8	14.25	25	25
12	FFG-300-475	RG-300-378	12.09	19.00	14.75	5/32	1/8	17.00	10	10
14	FFG-350-525	RG-350-445	14.12	21.00	17.15	5/32	1/8	18.75	10	10
16	FFG-400-588	RG-400-510	16.19	23.50	19.90	5/32	1/8	21.25	10	10
18	FFG-450-625	RG-450-542	18.25	25.00	21.15	5/32	1/8	22.75	10	10
20	FFG-500-688	RG-500-606	20.28	27.50	23.60	5/32	1/8	25.00	10	10
24	FFG-600-800	RG-600-717	24.34	32.00	27.95	5/32	1/8	29.50	10	10

FLAT FLANGE GASKET

Full Face

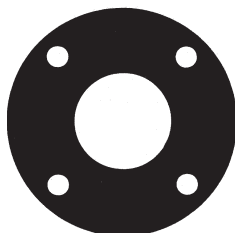

Ring Type

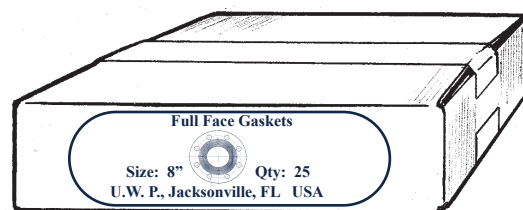

Material: Red Rubber
Non-Asbestos

Nominal Size	Part No. (Full Face) Red Rubber	Part No. (Ring) Red Rubber	Part No. (Full Face) Non-Asbestos	Part No. (Full Face) Non-Asbestos	OD (Full Face)	OD (Ring)	Thickness	Bolt Circle (Full Face)	Box Quantity (Full Face)	Box Quantity (Ring)
1	FFRG-010	RRG-010	FFNG-010	RNG-010	4.25	2.63	1/8	3.12	25	25
1-1/4	FFRG-012	RRG-012	FFNG-012	RNG-012	4.62	3.00	1/8	3.50	25	25
1-1/2	FFRG-015	RRG-015	FFNG-015	RNG-015	5.00	3.38	1/8	3.88	25	25
2	FFRG-020	RRG-020	FFNG-020	RNG-020	6.00	3.90	1/8	4.75	25	25
2 1/2	FFRG-025	RRG-025	FFNG-025	RNG-025	7.00	4.70	1/8	5.50	25	25
3	FFRG-030	RRG-030	FFNG-030	RNG-030	7.50	5.15	1/8	6.00	25	25
4	FFRG-040	RRG-040	FFNG-040	RNG-040	9.00	6.30	1/8	7.50	25	25
5	FFRG-050	RRG-050	FFNG-050	RNG-050	10.00	7.60	1/8	8.50	25	25
6	FFRG-060	RRG-060	FFNG-060	RNG-060	11.00	8.50	1/8	9.50	25	25
8	FFRG-080	RRG-080	FFNG-080	RNG-080	13.50	10.60	1/8	11.75	25	25
10	FFRG-100	RRG-100	FFNG-100	RNG-100	16.00	12.80	1/8	14.25	25	25
12	FFRG-120	RRG-120	FFNG-120	RNG-120	19.00	14.75	1/8	17.00	10	10
14	FFRG-140	RRG-140	FFNG-140	RNG-140	21.00	17.15	1/8	18.75	10	10
16	FFRG-160	RRG-160	FFNG-160	RNG-160	23.50	19.90	1/8	21.25	10	10
18	FFRG-180	RRG-180	FFNG-180	RNG-180	25.00	21.15	1/8	22.75	10	10
20	FFRG-200	RRG-200	FFNG-200	RNG-200	27.50	23.60	1/8	25.00	10	10
24	FFRG-240	RRG-240	FFNG-240	RNG-240	32.00	27.95	1/8	29.50	10	10
30	FFRG-300	-	-	-	38.75	-	1/8	36.00	5	-
36	FFRG-360	-	-	-	46.00	-	1/8	42.75	5	-
42	FFRG-420	-	-	-	53.00	-	1/8	49.50	5	-
48	FFRG-480	-	-	-	59.50	-	1/8	56.00	5	-

FLANGE ACCESSORY PACKS

Class 125 & Class 250

Flanges



Class 125/150 Flange Size	1/8" Full Face Seal-Tite (Serrated)	1/8" Ring Type Seal-Tite (Serrated)	1/8" Full Face Red Rubber	1/8" Ring Type Red Rubber	1/8" Full Face Non-Asbestos	1/8" Ring Type Non-Asbestos
1	FBR-010-*	RBP-010-*	FRP-010-*	RRP-010-*	FNP-010-*	RNP-010-*
1-1/4	FBR-012-*	RBP-012-*	FRP-012-*	RRP-012-*	FNP-012-*	RNP-012-*
1-1/2	FBR-015-*	RBP-015-*	FRP-015-*	RRP-015-*	FNP-015-*	RNP-015-*
2	FBR-020-*	RBP-020-*	FRP-020-*	RRP-020-*	FNP-020-*	RNP-020-*
2-1/2	FBR-025-*	RBP-025-*	FRP-025-*	RRP-025-*	FNP-025-*	RNP-025-*
3	FBR-030-*	RBP-030-*	FRP-030-*	RRP-030-*	FNP-030-*	RNP-030-*
4	FBR-040-*	RBP-040-*	FRP-040-*	RRP-040-*	FNP-040-*	RNP-040-*
5	FBR-050-*	RBP-050-*	FRP-050-*	RRP-050-*	FNP-050-*	RNP-050-*
6	FBR-060-*	RBP-060-*	FRP-060-*	RRP-060-*	FNP-060-*	RNP-060-*
8	FBR-080-*	RBP-080-*	FRP-080-*	RRP-080-*	FNP-080-*	RNP-080-*
10	FBR-100-*	RBP-100-*	FRP-100-*	RRP-100-*	FNP-100-*	RNP-100-*
12	FBR-120-*	RBP-120-*	FRP-120-*	RRP-120-*	FNP-120-*	RNP-120-*
14	FBR-140-*	RBP-140-*	FRP-140-*	RRP-140-*	FNP-140-*	RNP-140-*
16	FBR-160-*	RBP-160-*	FRP-160-*	RRP-160-*	FNP-160-*	RNP-160-*
18	FBR-180-*	RBP-180-*	FRP-180-*	RRP-180-*	FNP-180-*	RNP-180-*
20	FBR-200-*	RBP-200-*	FRP-200-*	RRP-200-*	FNP-200-*	RNP-200-*
24	FBR-240-*	RBP-240-*	FRP-240-*	RRP-240-*	FNP-240-*	RNP-240-*
30	-	-	FRP-300-*	RRP-300-*	FNP-300-*	RNP-300-*
36	-	-	FRP-360-*	RRP-360-*	FNP-360-*	RNP-360-*
42	-	-	FRP-420-*	RRP-420-*	FNP-420-*	RNP-420-*
48	-	-	FRP-480-*	RRP-480-*	FNP-480-*	RNP-480-*

*Add suffix "Z" for Zinc Plated, "304" for 304 Stainless Steel & "316" for 316 Stainless Steel

*Add suffix "G" for Galvanized Steel

*Add suffix "250" for Zinc Class 250 Flange Accessories

Hex Bolts and Nuts for Flanges to B16.1-125#, B16.5-150#

Material: Bolts - ASTM A307 Grade B, Nuts -ASTM A563, Grade A

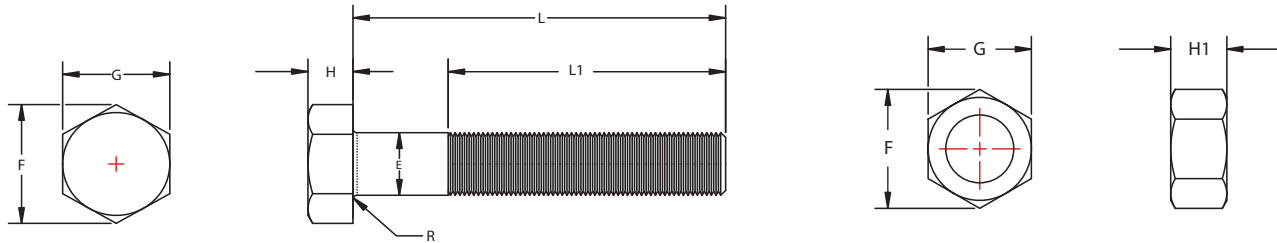

Nominal Size	Part No.	Threads per inch UNC	E	G	F	H	HI	R	L ₁	L
			Shaft Diameter	Width Across Flats	Max. Width Across Corners	Bolt Head Height	Nut Height	Radius of Fillet	Thread Length	Shaft Length
1/2 x 2	BN7025-050-200*	13	0.515	3/4	0.866	11/32	7/16	0.01~0.03	1.25	2.00
5/8 x 2-1/2	BN7025-062-250*	11	0.642	15/16	1.083	27/64	35/64	0.02~0.06	1.50	2.50
5/8 x 3	BN7025-062-300*	11	0.642	15/16	1.083	27/64	35/64	0.02~0.06	1.50	3.00
3/4 x 3-1/2	BN7025-075-350*	10	0.768	1-1/8	1.299	1/2	41/64	0.02~0.06	1.75	3.50
3/4 x 4-1/2	BN7025-075-450*	10	0.768	1-1/8	1.299	1/2	41/64	0.02~0.06	1.75	4.50
7/8 x 4	BN7025-082-400*	9	0.895	1-5/16	1.516	37/64	3/4	0.02~0.06	2.00	4.00
7/8 x 4-1/2	BN7025-082-450*	9	0.895	1-5/16	1.516	37/64	3/4	0.02~0.06	2.00	4.50
1 x 4-1/2	BN7025-100-450*	8	1.022	1-1/2	1.732	43/64	55/64	0.03~0.09	2.25	4.50
1 -1/8 x 5	BN7025-112-500*	8	1.149	1-11/16	1.949	3/4	31/32	0.03~0.09	2.50	5.00
1-1/8 x 5-1/2	BN7025-112-550*	8	1.149	1-11/16	1.949	3/4	1-1/16	0.03~0.09	2.50	5.50
1-1/4 x 6-1/2	BN7025-125-650*	8	1.277	1-7/8	2.165	27/32	1-9/32	0.03~0.09	2.75	6.50
1-1/2 x 7	BN7025-150-700*	8	1.531	2-1/4	2.598	1	1-9/32	0.03~0.09	3.25	7.00
1-1/2 x 7-1/2	BN7025-150-750*	8	1.531	2-1/4	2.598	1	1-9/32	0.03~0.09	3.25	7.50
1-1/2 x 8	BN7025-150-800*	8	1.531	2-1/4	2.598	1	1-9/32	0.03~0.09	3.25	8.00

Packaged Bolt & Nut Packs (Water Resistant)

Part No.	Class 125/150 Flange Size	Bolt Diameter and Length	No. of Bolts per Flange	No. of Bolts per Poly Bag	Master Box (Qty. of Sets)
FBZ015	1	1/2 x 2	4	4	64
	1-1/4				
FBZ03	2	5/8 x 2-1/2	4	4	20
	3				
FBZ04	4	5/8 x 3	8	8	16
FBZ08	5	3/4 x 3-1/2	8	8	8
	6				
FBZ12	8	7/8 x 4	12	12	4
	10				
FBZ14	12	1 x 4-1/2	12	12	1
	14				
FBZ16	16	1 x 4-1/2	16	16	1
FBZ18	18	1-1/8 x 5	16	16	1
FBZ20	20	1-1/8 x 5	20	20	1
FBZ24	24	1-1/4 x 5-1/2	20	20	1
FBZ30	30	1-1/4 x 6-1/2	28	14	2 boxes
FBZ36	36	1-1/2 x 7	32	8	4 boxes
FBZ42	42	1-1/2 x 7-1/2	36	9	4 boxes
FBZ48	48	1-1/2 x 8	44	11	4 boxes

1. Heavy hex head steel bolts to ANSI B18.2.1 with heavy hex steel nuts to ANSI B18.2.2. Bolts to be threaded to ANSI B1.1 unified inch screw threads, class 2A external & Class 2B internal. The steel material to conform to ASTM A307 specification for carbon steel externally threaded standard fasteners, Grade B.
2. Zinc Plated per ASTM B633.

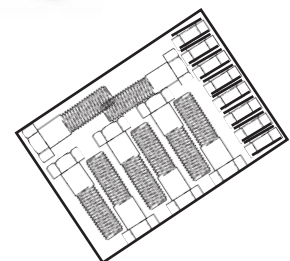

Stainless Steel Hex Bolts and Nuts For Flanges to B16.1-125#, B16.5-150# SS 304 and SS 316

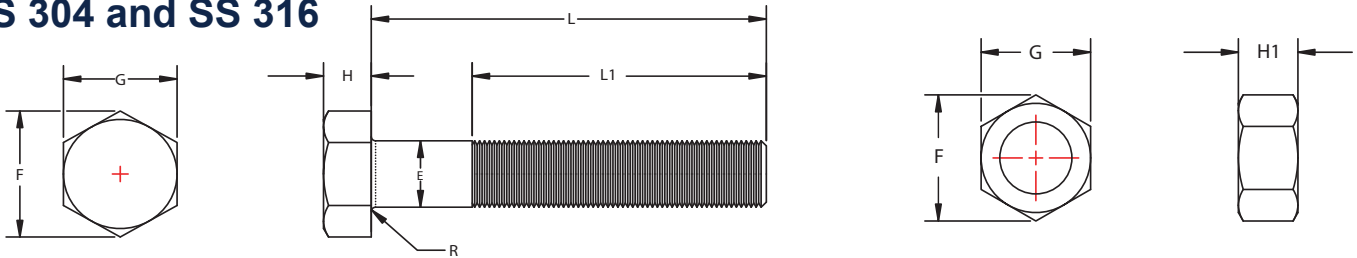

Nominal Size	Part No.	E	G	F	H	HI	R	L ₁	L
		Body Diameter	Width Across Flats	Max. Width Across Corners	Bolt Head Height	Nut Height	Radius of Fillet	Thread Length	Shaft Length
1/2 x 2	BN6025-050-200*	0.515	3/4	0.866	11/32	7/16	0.01-0.03	1.25	2.00
5/8 x 2-1/2	BN6025-062-250*	0.642	15/16	1.083	27/64	35/64	0.02-0.06	1.50	2.50
5/8 x 3	BN6025-062-300*	0.642	15/16	1.083	27/64	35/64	0.02-0.06	1.50	3.00
3/4 x 3-1/2	BN6025-075-350*	0.768	1-1/8	1.299	1/2	41/64	0.02-0.06	1.75	3.50
3/4 x 4-1/2	BN6025-075-450*	0.768	1-1/8	1.299	1/2	41/64	0.02-0.06	1.75	4.50
7/8 x 4	BN6025-082-400*	0.895	1-5/16	1.516	37/64	3/4	0.02-0.06	2.00	4.00
7/8 x 4-1/2	BN6025-082-450*	0.895	1-5/16	1.516	37/64	3/4	0.02-0.06	2.00	4.50
1 x 4-1/2	BN6025-100-450*	1.022	1-1/2	1.732	43/64	55/64	0.03-0.09	2.25	4.50
1-1/8 x 5	BN6025-112-500*	1.149	1-11/16	1.949	3/4	31/32	0.03-0.09	2.50	5.00
1-1/8 x 5-1/2	BN6025-112-550*	1.149	1-11/16	1.949	3/4	1-1/16	0.03-0.09	2.50	5.50
1-1/4 x 6-1/2	BN6025-125-650*	1.277	1-7/8	2.165	27/32	1-9/32	0.03-0.09	2.75	6.50
1-1/2 x 7	BN6025-150-700*	1.531	2-1/4	2.598	1	1-9/32	0.03-0.09	3.25	7.00
1-1/2 x 7-1/2	BN6025-150-750*	1.531	2-1/4	2.598	1	1-9/32	0.03-0.09	3.25	7.50
1-1/2 x 8	BN6025-150-800*	1.531	2-1/4	2.598	1	1-9/32	0.03-0.09	3.25	8.00

*Add suffix 304 or 316 to specify stainless steel type.



1. Hex head stainless steel bolts to ANSI B18.2.1 with hex stainless steel nuts to ANSI B18.2.2. Bolts to be threaded to ANSI B1.1 unified inch screw threads, Class 2A external & Class 2B internal. The stainless steel material is available in either Type 304 or Type 316.

Packaged Bolt & Nut Packs (Water Resistant)

Stainless Steel 304

Class 125/150 Flange Size	Part No.	Bolt Diameter and Length	No. of Bolts per Flange	No. of Bolts per Poly Bag	Master Box (Qty. of Sets)
2					
2-1/2	FBS03-304	5/8 x 2-1/2	4	4	20
3					
4	FBS04-304	5/8 x 3	8	8	16
5					
6	FBS08-304	3/4 x 3-1/2	8	8	8
8					
10	FBS12-304	7/8 x 4	12	12	4
12					
14	FBS14-304	1" x 4-1/2"	12	12	1
16	FBS16-304	1" x 4-1/2"	16	16	1
18	FBS18-304	1-1/8" x 5"	16	16	1
20	FBS20-304	1-1/8" x 5"	20	20	1
24	FBS24-304	1-1/4" x 5-1/2"	20	20	1
30	FBS30-304	1-1/4" x 6-1/2"	28	14	2 boxes
36	FBS36-304	1-1/2" x 7"	32	8	4 boxes
42	FBS42-304	1-1/2" x 7-1/2"	36	9	4 boxes
48	FBS48-304	1-1/8" x 8"	44	11	4 boxes

Stainless Steel 316

Class 125/150 Flange Size	Part No.	Bolt Diameter and Length	No. of Bolts per Flange	No. of Bolts per Poly Bag	Master Box (Qty. of Sets)
2					
2-1/2	FBS03-316	5/8 x 2-1/2	4	4	20
3					
4	FBS04-316	5/8 x 3	8	8	16
5					
6	FBS08-316	3/4 x 3-1/2	8	8	8
8					
10	FBS12-316	7/8 x 4	12	12	4
12					
14	FBS14-316	1" x 4-1/2"	12	12	1
16	FBS16-316	1" x 4-1/2"	16	16	1
18	FBS18-316	1-1/8" x 5"	16	16	1
20	FBS20-316	1-1/8" x 5"	20	20	1
24	FBS24-316	1-1/4" x 5-1/2"	20	20	1
30	FBS30-316	1-1/4" x 6-1/2"	28	14	2 boxes
36	FBS36-316	1-1/2" x 7"	32	8	4 boxes
42	FBS42-316	1-1/2" x 7-1/2"	36	9	4 boxes
48	FBS48-316	1-1/8" x 8"	44	11	4 boxes

Stud Bolts/Nuts

STUD BOLTS				NUTS			
Bolt Size	Part No. Zinc Plated (B7)	Part No. SS304	Part No. SS316	Nut Size	Part No. Zinc Plated (2H)	Part No. SS304	Part No. SS316
1/2" x 2"	8025-050-200	8025-050-200-304	8025-050-200-316	1/2"	8035-050	8035-050-304	8035-050-316
5/8" x 2-1/2"	8025-062-250	8025-062-250-304	8025-062-250-316	5/8"	8035-062	8035-062-304	8035-062-316
5/8" x 3"	8025-062-300	8025-062-300-304	8025-062-300-316				
5/8" x 3-1/2"	8025-062-350	8025-062-350-304	8025-062-350-316				
5/8" x 6"	8025-062-600	8025-062-600-304	8025-062-600-316				
3/4" x 3"	8025-075-300	8025-075-300-304	8025-075-300-316				
3/4" x 3-1/2"	8025-075-350	8025-075-350-304	8025-075-350-316	3/4"	8035-075	8035-075-304	8035-075-316
3/4" x 4"	8025-075-400	8025-075-400-304	8025-075-400-316				
3/4" x 4-1/2"	8025-075-450	8025-075-450-304	8025-075-450-316				
3/4" x 5"	8025-075-500	8025-075-500-304	8025-075-500-316				
3/4" x 5-1/2"	8025-075-550	8025-075-550-304	8025-075-550-316				
3/4" x 6"	8025-075-600	8025-075-600-304	8025-075-600-316				
3/4" x 7"	8025-075-700	8025-075-700-304	8025-075-700-316				
7/8" x 3-1/2"	8025-082-350	8025-082-350-304	8025-082-350-316	7/8"	8035-082	8035-082-304	8035-082-316
7/8" x 3-3/4"	8025-082-375	8025-082-375-304	8025-082-375-316				
7/8" x 8"	8025-082-800	8025-082-800-304	8025-082-800-316				
1" x 4"	8025-100-400	8025-100-400-304	8025-100-400-316	1"	8035-100	8035-100-304	8035-100-316
1" x 5"	8025-100-500	8025-100-500-304	8025-100-500-316				
1" x 6"	8025-100-600	8025-100-600-304	8025-100-600-316				
1-1/8" x 4-1/2"	8025-112-450	8025-112-450-304	8025-112-450-316	1-1/8"	8035-112	8035-112-304	8035-112-316
1-1/8" x 5"	8025-112-500	8025-112-500-304	8025-112-500-316				
1-1/4" x 5"	8025-125-500	8025-125-500-304	8025-125-500-316				
1-1/4" x 6"	8025-125-600	8025-125-600-304	8025-125-600-316	1-1/4"	8035-125	8035-125-304	8035-125-316
1-1/4" x 7"	8025-125-700	8025-125-700-304	8025-125-700-316				
1-1/2" x 6"	8025-150-600	8025-150-600-304	8025-150-600-316	1-1/2"	8035-150	8035-150-304	8035-150-316
1-1/2" x 7"	8025-150-700	8025-150-700-304	8025-150-700-316				

Material:

Bolts:
 Zinc Plated Steel, Grade B7
 Stainless Steel 304
 Stainless Steel 316

Nuts:
 Zinc Plated Steel, Grade 2H
 Stainless Steel 304
 Stainless Steel 316

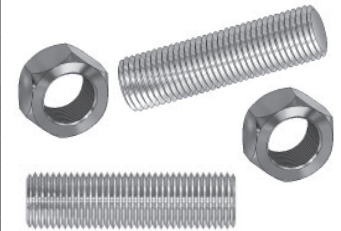

Packaged Flange Stud Bolt Packs for use with Class 125/150 Flange Pipe

Flange Size	Part No. Carbon Steel	Part No. SS304	Part No. SS316	Bolt Size	No. of Bolts/ Nuts per Flange	No. of Bolts/ Nuts per Polybag	Master Box (No. of Packs)
2"	FSB03	FSB03-304	FSB03-316	5/8" x 3"	4	4	20
2-1/2"							
3"							
4"	FSB04	FSB04-304	FSB04-316	5/8" x 3"	8	8	16
5"	FSB08	FSB08-304	FSB08-316	3/4" x 3-1/2"	8	8	8
6"							
8"							
10"	FSB12	FSB12-304	FSB12-316	7/8" x 3-1/2"	12	12	4
12"							
14"	FSB14	FSB14-304	FSB14-316	1" x 4"	12	12	1
16"	FSB16	FSB16-304	FSB16-316	1" x 4"	16	16	1
18"	FSB18	FSB18-304	FSB18-316	1-1/8" x 4-1/2"	16	16	1
20"	FSB20	FSB20-304	FSB20-316	1-1/8" x 4-1/2"	20	20	1
24"	FSB24	FSB24-304	FSB24-316	1-1/4" x 5"	20	20	1
30"	FSB30	FSB30-304	FSB30-316	1-1/4" x 5"	28	14	2 boxes (1 pack each box)
36"	FSB36	FSB36-304	FSB36-316	1-1/2" x 6"	32	8	4 boxes (1 pack each box)
42"	FSB42	FSB42-304	FSB42-316	1-1/2" x 6"	36	9	4 boxes (1 pack each box)
48"	FSB48	FSB48-304	FSB48-316	1-1/2" x 7"	44	11	4 boxes (1 pack each box)

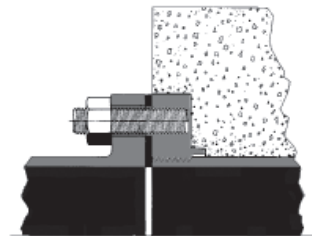

FLANGE DETAILS - Class 250

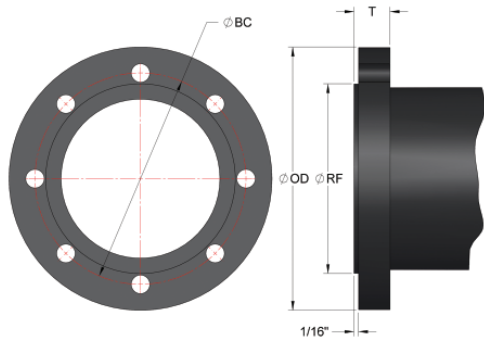

Size	OD	T	RF	BC	Bolt Hole Dia.	Bolt Dia. & Length	No. of Bolts
3	8-1/4	1.12	5-11/16	6-5/8	7/8	3/4 x 3-1/2	8
4	10	1.25	6-15/16	7-7/8	7/8	3/4 x 3-3/4	8
5	11	1.38	8-5/16	9-1/4	7/8	3/4 x 4	8
6	12-1/2	1.44	9-11/16	10-5/8	7/8	3/4 x 4	12
8	15	1.62	11-15/16	13	1	7/8 x 4-1/4	12
10	17-1/2	1.88	14-1/16	15-1/4	1-1/8	1 x 5-1/4	16
12	20-1/2	2.00	16-7/16	17-3/4	1-1/4	1-1/8 x 5-1/2	16

ELBOWS

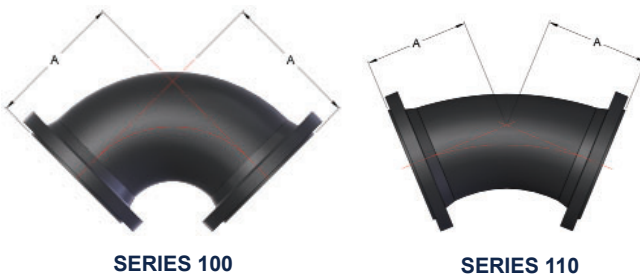

Size	90° Elbow			45° Elbow		
	Part No.	A	Wgt.	Part No.	A	Wgt.
3	100F-0303-	6	40	110F-0303-	3-1/2	35
4	100F-0404-	7	66	110F-0404-	4-1/2	60
6	100F-0606-	8-1/2	124	110F-0606-	5-1/2	103
8	100F-0808-	10	192	110F-0808-	6	158
10	100F-1010-	11-1/2	311	110F-1010-	7	247
12	100F-1212-	13	430	110F-1212-	8	355

90° REDUCING ELBOW

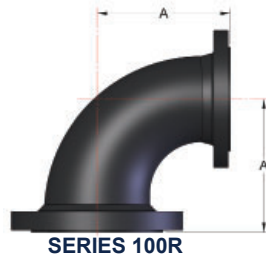

Size	Part No.	A	Weight
6 x 4	100F-0604-	8-1/2	95
8 x 6	100F-0806-	10	161
10 x 8	100F-1008-	11-1/2	240

TEES

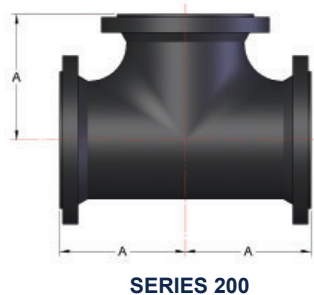

Size	Part No.	A	Weight
3	200F-0303-	6	58
4	200F-0404-	7	98
6	200F-0606-	8-1/2	184
8	200F-0808-	10	280
10	200F-1010-	11-1/2	435
12	200F-1212-	13	599

REDUCING TEES



Size	Part No.	A	Weight
6 x 6 x 4	200F-0604-	8-1/2	150
8 x 8 x 6	200F-0806-	10	246
10 x 10 x 6	200F-1006-	11-1/2	375
10 x 10 x 8	200F-1008-	11-1/2	405
12 x 12 x 6	200F-1206-	13	435
12 x 12 x 8	200F-1208-	13	445

Add suffix "C" for Grey Cast Iron - "D" for Ductile Cast Iron

Larger sizes thru 48" available upon request.

REDUCERS (Concentric/Eccentric)

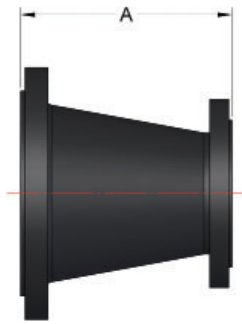

SERIES 500



SERIES 510

Size	Part No. (Concentric)	Part No. (Eccentric)	A	Weight
4 x 3	500F-0403-	510F-0403-	7	40
6 x 3	500F-0603-	510F-0603-	9	70
6 x 4	500F-0604-	510F-0604-	9	77
6 x 5	500F-0605-	510F-0605-	9	85
8 x 5	500F-0805-	510F-0805-	11	135
8 x 6	500F-0806-	510F-0806-	11	142
10 x 6	500F-1006-	510F-1006-	12	185
10 x 8	500F-1008-	510F-1008-	12	196
12 x 6	500F-1206-	510F-1206-	14	235
12 x 8	500F-1208-	510F-1208-	14	260
12 x 10	500F-1210-	510F-1210-	14	275

BLIND FLANGES

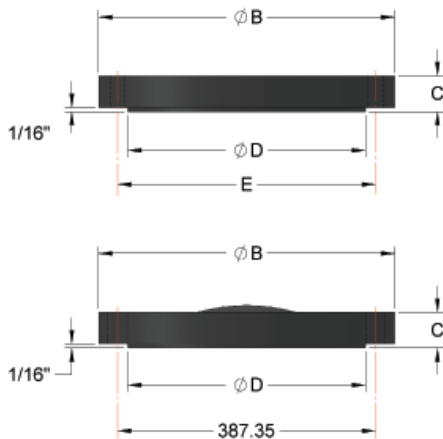

SERIES 600

Nominal Pipe Size	Flange Size	Part No.	C	B	D	E	Weight
3	3 x 8-1/4	600F-0303-	1-3/16	8-1/4	5-11/16	6-5/8	14
4	4 x 10	600F-0404-	1-1/4	10	6-15/16	7-7/8	25
6	6 x 12-1/2	600F-0606-	1-7/16	12-1/2	9-11/16	10-5/8	43
8	8 x 15	600F-0808-	1-5/8	15	1-15/16	13	69
10	10 x 17-1/2	600F-1010-	1-7/8	17-1/2	14-1/16	15-1/4	100
12	12 x 20-1/2	600F-1212-	2	20-1/2	16-7/16	17-3/4	148

Dished faces for use with 10" and 12" extra heavy Blind Flanges.

THREADED FLANGES

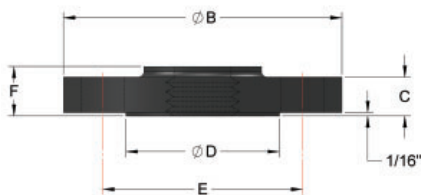

SERIES 760

Nominal Pipe Size	Flange Size	Part No.	C	B	D	E	F	Weight
1	1 x 4-7/8	760-0100-0488-	11/16	4-7/8	2-11/16	3-1/2	7/8	3
1-1/4	1-1/4 x 5-1/2	760-0125-0525-	3/4	5-1/4	3-1/16	3-7/8	1	4
1-1/2	1-1/2 x 6-1/8	760-0150-0612-	13/16	6-1/8	3-5/16	4-1/2	1-1/8	6
2	2 x 6-1/2	760-0200-0650-	7/8	6-1/2	4-3/16	5	1-3/4	7
2-1/2	2-1/2 x 7-1/2	760-0250-0750-	1	7-1/2	4-15/16	5-7/8	1-7/16	10
3	3 x 8-1/4	760-0300-0825-	1-1/8	8-1/4	5-11/16	6-5/8	1-11/16	12.8
4	4 x 10	760-0400-1000-	1-1/4	10	6-15/16	7-7/8	1-3/4	22.5
6	6 x 12-1/2	760-0600-1250-	1-7/16	12-1/2	9-11/16	10-5/8	1-15/16	34.2
8	8 x 15	760-0800-1500-	1-5/8	15	11-15/16	13	2-3/16	55
10	10 x 17-1/2	760-1000-1750-	1-7/8	17-1/2	14-1/16	15-1/4	2-3/8	77
12	12 x 20 -1/2	760-1200-2050-	2	20-1/2	16-7/16	17-3/4	2-9/16	103

Add suffix "C" for Grey Cast Iron - "D" for Ductile Cast Iron

Larger sizes thru 48" available upon request.



UNITED Water Products
A PUPCO Brand

8710 Air Park West Drive
Charlotte, NC 28214
TEL. 877-766-4459
Website: www.unitedwaterproducts.com